



BIEWER LUMBER™
FRTW
FIRE RETARDANT SPECIALISTS

Exterior Wall Assembly

FlamePRO®
FIRE RETARDANT TREATED WOOD



bieterlumber.com
800.482.5717

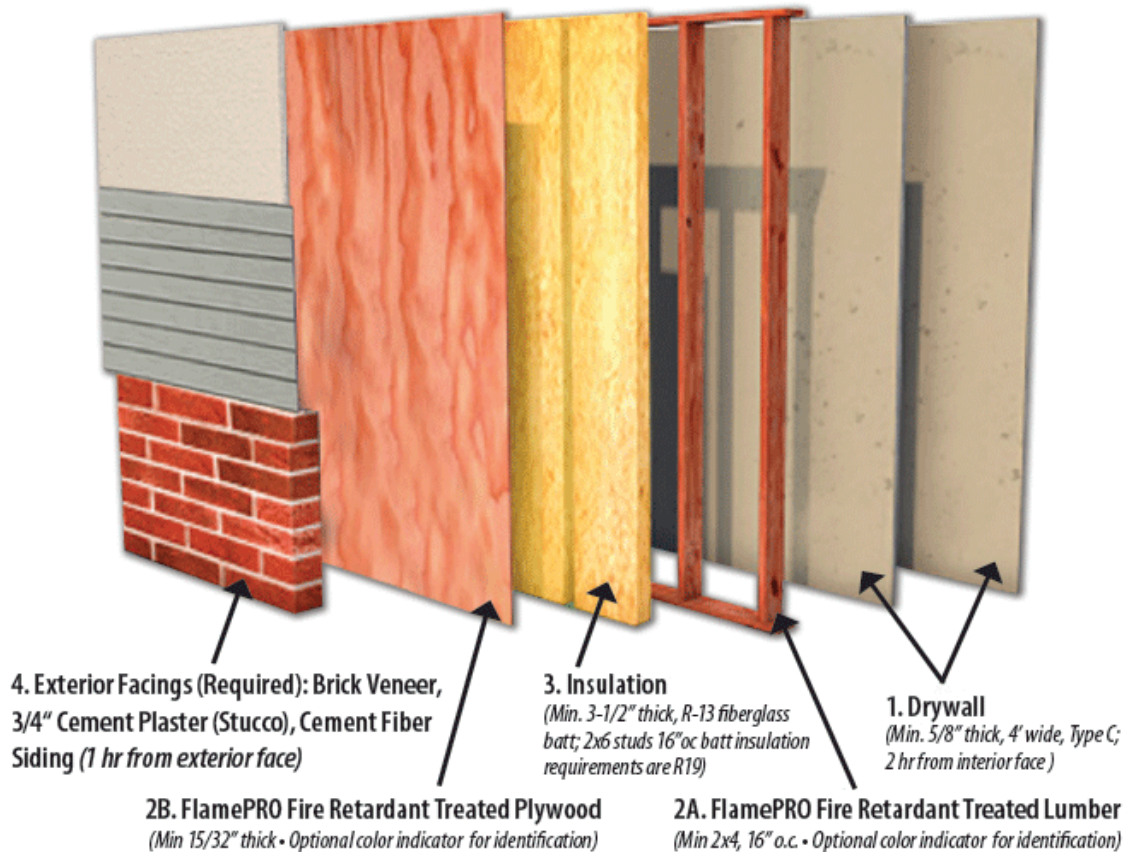

2 Hour Tested Exterior Wall Assembly (120-02)

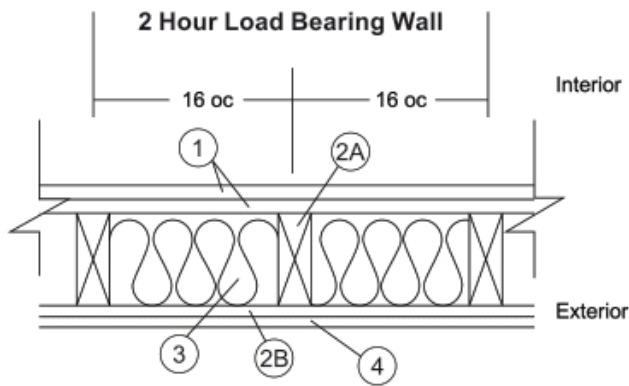

- 1. Drywall** (2 hr from interior face)
- 2A. FlamePRO Lumber**
- 2B. FlamePRO Plywood**
- 3. Insulation**
- 4. Exterior Facings (Required):**
Brick Veneer, 3/4" Cement Plaster (Stucco), Cement Fiber Siding (1 hr from exterior face)

Max. Tested Load:
100% of Design Load

Fire Ratings:
2 hour load bearing rated from interior and 1 hour load bearing exterior. For details refer to ESR Report 4244.

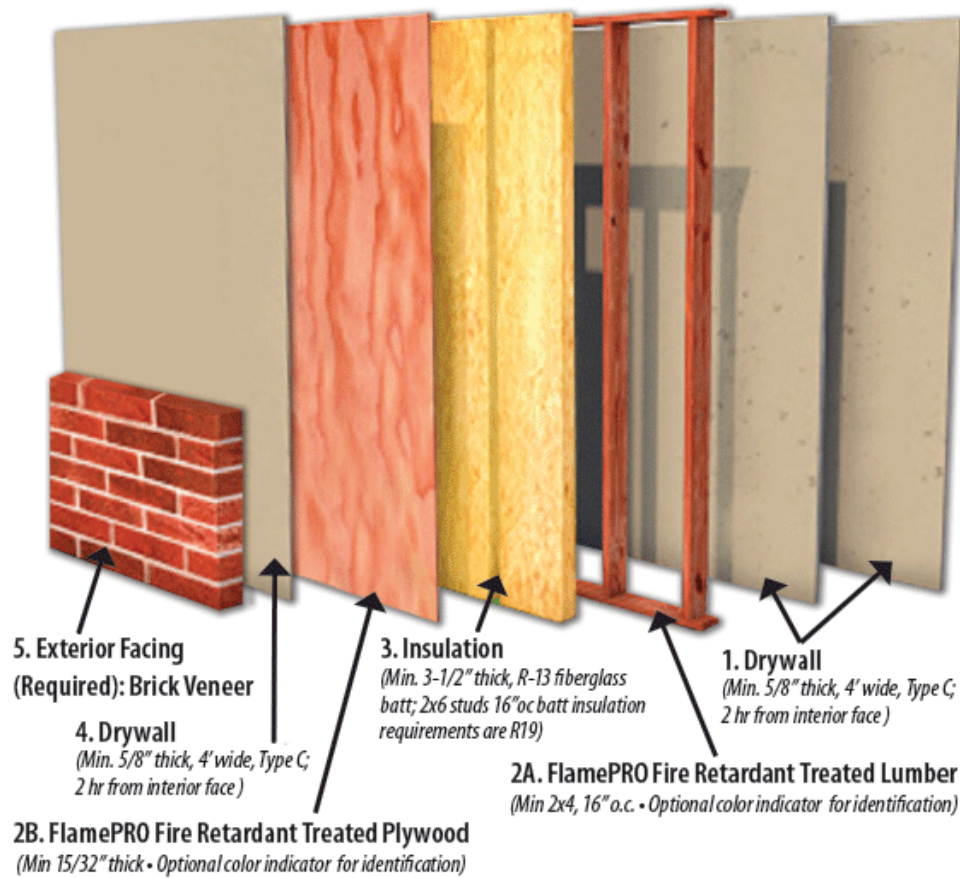

2 Hour Tested Exterior Wall Assembly (120-03)

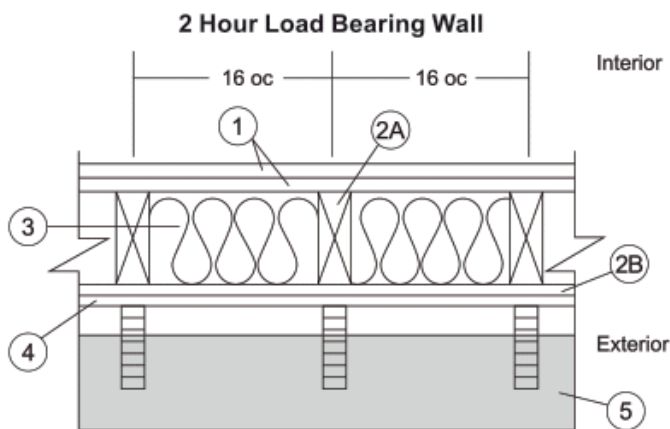

- 1. Drywall (2 hr from interior face)
- 2A. FlamePRO Lumber
- 2B. FlamePRO Plywood
- 3. Insulation
- 4. Drywall
- 5. Exterior Facings (Required):
Brick Veneer

Max. Tested Load:
100% of Design Load

Fire Ratings:
2 hour load bearing.